

The Crystal Structure of Würster's Red Bromide

BY JIRO TANAKA AND NORIYOSHI SAKABE

Department of Chemistry, Nagoya University, Chikusa, Nagoya, Japan

(Received 25 October 1967 and in revised form 8 December 1967)

Würster's red bromide (*N,N*-dimethyl-*p*-phenylenediamine bromide) crystallizes in the orthorhombic system with $a=6.38$, $b=22.48$, $c=6.21$ Å; the space group is *Cmcm* and $Z=4$. The cation radicals form a covalent and charge-resonance bonded column parallel to c with interplanar spacing of 3.105 Å. The interplanar spacings are all equidistant.

Recently, several investigations have been described on the electronic properties of crystals containing organic free radicals, but little consideration has so far been given to their physico-chemical properties in relation to the crystal structure. The structure of Würster's radical is of particular interest from the viewpoint of interaction in crystals, since the covalent and charge-resonance bonding between the radicals may enhance the binding, while the ionic force may tend to increase the repulsion between the radicals. In the present paper we report the structure of Würster's red bromide (*N,N*-dimethyl-*p*-phenylenediamine bromide):

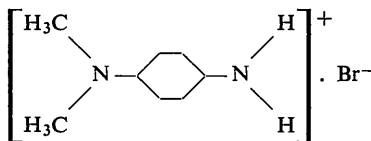

The spectroscopic and electronic properties of this crystal will be discussed in a separate paper. An earlier structure study by Turner & Albrecht (1955) on the structure of Würster's blue perchlorate has not yet been published, and, therefore, the present result will throw light on the structure and the packing of Würster's radical in the crystal.

Experimental

The crystal was obtained by the oxidation of the free amine by bromine and the recrystallization from methanol. In polarized light, the crystal exhibited pleochroism with colours ranging from dark green to pale green. The maximum absorption of light was found when the electric vector was parallel to the needle axis. Two different crystals were used in the X-ray investigation. One $0.2 \times 0.1 \times 0.06$ mm in dimensions, was mounted about its needle c axis. The second crystal was cut into a roughly square rhomb and was mounted along the a axis. Unit-cell dimensions were obtained from zero-layer Weissenberg photographs about the principal axes. On multiple-film equi-inclination Weissenberg photographs, the intensities were estimated visually on the layer lines 0–4 about c and on the layer lines 0–2 about a . Of a total 575 reflexions within the effective sphere of copper radiation, 471 reflexions

were collected. No corrections were made for absorption and extinction since both the crystals used were sufficiently small.

Crystal data

$[(\text{CH}_3)_2\text{NC}_6\text{H}_4\text{NH}_2]^+\text{Br}^-$,
 $M=216.1$ Orthorhombic,
 $a=6.38 \pm 0.01$, $b=22.48 \pm 0.04$, $c=6.21 \pm 0.01$ Å
 at 30°C . $V=925.3$ Å³, $Z=4$, $F(000)=436$
 $\text{CuK}\alpha=1.542$ Å $\mu=60.02$ cm⁻¹

Absent spectra:

hkl when $h+k$ odd
 $h0l$ when h and l odd
 $0kl$ when k odd
 $(h00)$ when h odd

Space group *Cmc*2₁, *Cmcm* or *C2cm*.

The crystal density, determined by the flotation method with a mixture of carbon tetrachloride and benzene, was 1.58 g.cm⁻³, while the calculated density for four molecules per unit cell is 1.61 g.cm⁻³.

Structure analysis

The space group *Cmcm* was assumed. This was indeed verified later by intensity calculation. In the space group *Cmcm*, which has 16-fold general positions, the four molecules in the cell must occupy the special positions. In order to satisfy this requirement, the bromine atom and the twofold molecular axis should be on the (001) plane and the molecular plane should be perpendicular to the [001] direction. In addition to this the z coordinates of all atoms in the space group *Cmcm* should be 0.25, since otherwise there are more than four atomic positions in the general coordinates.

The coordinates of bromine atoms were found from the three-dimensional Patterson map, and the positions of all other atoms were estimated by the minimum function method. Using these trial coordinates, three-dimensional least-squares refinement with isotropic temperature factors was initiated. After several cycles of refinement the calculated R index became 0.12. Further refinement was carried out by the full-matrix least-squares method, in which 39 parameters (11 atom-

ic coordinates of 8 atoms, 27 anisotropic temperature factors) were adjusted. The final R value was 0.108. The final parameters are listed in Table 1; the observed and calculated structure factors are listed in Table 2. In Fig. 1 is shown the electron density in the (001) plane at the final stage of the refinement. The absence of residual peaks in the Fourier map confirms the present choice of the space group. All calculations were performed at the Computational Center of the University of Tokyo by the UNICS program.

Table 1. Atomic parameters

Standard deviations are in parentheses.

	x	y	z
Br	0.0000 (0)	0.1327 (1)	0.2500 (0)
N(1)	0.0000 (0)	0.5728 (11)	0.2500 (0)
N(2)	0.0000 (0)	0.3345 (11)	0.2500 (0)
C(1)	0.0000 (0)	0.5179 (11)	0.2500 (0)
C(2)	0.8106 (33)	0.4847 (8)	0.2500 (0)
C(3)	0.8083 (36)	0.4263 (9)	0.2500 (0)
C(4)	0.0000 (0)	0.3925 (13)	0.2500 (0)
C(7)	0.8095 (41)	0.2993 (10)	0.2500 (0)

Results and discussion

Geometry of the N,N -dimethyl- p -phenylenediamine cation

The standard deviations in the atomic coordinates correspond to positional uncertainties of about 0.02 Å for all the atoms except bromine. Standard deviations of interatomic distances, then, are in the vicinity of 0.04 Å. The bond lengths and bond angles of the radical cation are shown in Fig. 2. The bond length in the benzene ring shows an apparent bond length alternation, which means that the resonance structures:

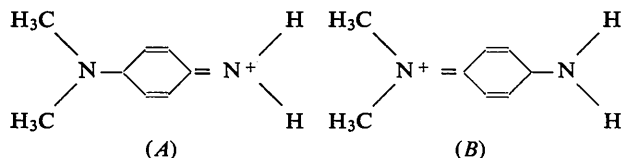

will be the most significant in determining the conformation of the radical. Comparison of the bond lengths between the C(1)-N(1) and the C(4)-N(2) atoms in Fig. 2 may indicate that structure (A) is slightly more important than structure (B), but the localization of

Table 2. Observed and calculated structure factors

H 0 0	H 8 0	H 16 0	H 25 0
2 95.1 111.3	0 59.6 64.2	0 48.1 49.4	1 14.6 13.8
4 107.8 106.7	2 99.6 97.3	2 28.1 30.0	H 26 0
6 74.7 69.7	4 58.3 51.9	4 27.4 28.8	2 21.4 24.0
8 11.2 13.2	6 27.1 29.7	6 14.7 16.4	H 27 0
H 1 0	H 9 0	H 17 0	H 28 0
1 24.2 17.7	1 31.7 34.5	3 11.4 11.3	0 20.2 22.3
3 62.3 65.4	3 32.2 34.9	5 10.5 2.8	2 21.4 24.0
7 15.1 17.2	5 8.8 12.6	H 18 0	1 16.0 16.8
H 2 0	H 10 0	H 19 0	H 21 1
2 8.2 7.6	2 51.4 49.8	2 22.3 21.6	0 7.7 7.7
6 7.1 7.6	4 19.4 3.7	4 24.7 25.8	
H 3 0	6 65.6 55.6	6 12.6 17.0	
1 92.2 98.1	4 27.0 20.9	H 20 0	
3 51.4 56.4	4 4.6 7.7	H 11 0	
5 51.9 46.2	H 11 0	1 50.6 44.7	1 121.4 130.4
7 19.8 20.9	1 105.3 105.6	3 43.8 40.9	3 54.8 47.3
H 4 0	3 69.6 61.4	H 20 0	5 52.5 56.1
0 84.3 108.	5 46.3 55.7	2 31.8 37.4	7 20.8 18.2
2 128.2 135.8	7 15.4 20.2	2 30.2 36.2	H 2 1
4 80.9 75.1	H 12 0	H 21 0	0 53.9 47.9
6 31.4 33.9	2 27.3 40.8	1 24.4 27.0	2 126.4 125.3
8 10.3 23.	4 43.9 46.4	3 12.7 11.0	4 65.1 58.7
H 5 0	6 13.0 18.4	5 12.9 16.6	8 17.0 25.6
1 73.6 69.9	H 13 0	H 22 0	H 3 1
3 24.3 19.3	1 31.7 27.3	2 10.5 5.2	1 64.9 69.2
5 32.6 35.7	3 13.5 11.1	4 28.4 27.7	3 33.3 30.7
7 9.8 11.1	5 6.9 14.3	4 11.0 14.0	5 33.3 36.0
H 6 0	H 14 0	H 23 0	7 11.3 11.8
0 36.0 45.1	1 44.4 41.2	H 4 1	
2 25.8 27.3	3 19.4 22.7	0 12.6 2.0	
4 22.7 21.3	2 25.6 25.6	2 18.3 18.6	
6 9.8 12.	4 14.8 22.7	6 4.3 4.6	
H 7 0	H 15 0	H 5 1	
1 112.0 104.9	2 13.3 11.6	1 118.4 123.6	
3 53.7 52.3	4 12.5 11.4	3 115.3 114.1	
5 90.7 90.3	1 63.5 61.6	5 38.9 42.2	
7 17.5 19.5	3 67.5 72.3	7 26.9 31.0	
	5 21.4 23.9		
H 6 1	H 14 1	H 23 1	H 4 2
0 128.9 133.9	0 52.1 55.8	1 4.0 6.6	0 102.9 88.5
2 33.9 35.5	2 46.1 44.8	3 10.7 11.8	2 127.0 103.2
4 18.0 18.6	4 27.4 31.8	H 24 1	4 75.1 50.2
6 32.6 35.8	6 19.7 20.6	0 33.1 33.7	6 33.3 30.7
H 7 1	H 15 1	0 21.2 18.5	H 5 2
1 40.0 40.0	1 13.2 10.5	4 18.0 18.9	1 105.5 94.6
3 34.8 32.2	3 29.7 29.1	H 25 1	3 26.5 19.9
5 15.5 14.3	5 4.0 1.0	0 27.2 28.1	5 39.0 30.6
7 14.9 16.1	H 16 1	3 16.5 22.2	7 6.4 10.
H 8 1	H 16 1	H 26 1	H 6 2
0 51.6 44.9	0 37.3 33.9	0 26.1 27.8	0 38.5 36.
2 18.7 23.1	2 84.8 79.5	2 12.1 7.8	2 23.1 23.7
4 23.1 21.4	4 39.7 39.8	H 27 1	4 26.5 18.8
6 13.7 14.8	6 14.4 15.6	0 15.4 9.7	6 6.0 10.9
H 9 1	H 17 1	H 28 1	H 7 2
1 74.4 79.4	1 42.4 39.2	0 16.8 16.1	1 96.3 82.9
3 75.3 77.0	3 27.5 31.5	H 18 1	3 50.2 47.1
5 31.3 35.3	H 18 1	0 30.5 35.7	5 51.0 42.6
7 19.6 23.5	H 10 1	2 34.5 49.6	7 20.3 17.3
H 10 1	H 10 1	4 29.5 28.2	H 8 2
0 80.1 84.5	0 80.1 84.5	6 12.9 15.1	0 71.2 60.5
2 68.0 67.6	2 68.0 67.6	H 19 1	2 87.2 77.5
4 52.3 51.4	4 52.3 51.4	0 225.6 260.4	4 34.0 46.5
6 26.0 28.0	6 26.0 28.0	2 106.6 93.6	6 35.9 27.
H 11 1	H 11 1	4 100.2 88.6	H 9 2
1 23.2 25.9	1 6.9 6.1	6 59.2 60.	1 30.4 28.1
3 13.6 15.1	3 12.8 11.1	H 1 2	3 29.6 28.5
5 3.9 3.3	H 20 1	1 10.5 0.	5 10.3 10.7
H 12 1	H 20 1	3 65.4 54.2	7 8.7 7.1
0 65.4 62.7	0 65.4 62.7	7 16.0 15.1	H 10 2
2 30.4 32.9	2 30.4 32.9	H 2 2	0 5.1 6.6
4 28.0 30.8	4 28.0 30.8	H 21 1	2 47.4 43.1
6 15.9 17.8	6 15.9 17.8	0 15.0 8.1	4 23.2 18.2
H 13 1	H 13 1	6 4.4 6.6	6 6.7 7.0
1 72.0 63.3	1 72.0 63.3	H 3 2	H 11 2
3 48.9 51.3	3 48.9 51.3	1 85.9 76.8	1 87.6 87.5
5 25.7 32.4	5 25.7 32.4	3 53.2 47.7	3 55.6 53.6
7 15.8 20.4	7 15.8 20.4	4 46.8 40.8	5 44.8 46.2
		7 21.2 18.3	7 18.9 18.1

Fig. 1. Electron density section on (001) at $z=0.25$.

Table 2 (cont.)

H 12 2	H 21 2	H 4 3	H 12 3	3 K 5
2 27.7 37.3	1 23.8 22.8	2 7.1 5.8	0 39.5 43.1	1 28.0 26.8
3 44.6 42.3	3 11.6 9.4	3 15.3 6.6	2 24.8 25.3	2 21.0 18.4
4 30.6 27.7	4 17.0 14.4	H 5 3	3 23.0 23.1	3 46.1 41.9
6 14.2 16.3	H 22 2	H 5 3	4 15.5 13.9	4 24.5 21.3
H 13 2	0 8.0 6.2	1 85.2 80.2	H 13 3	5 33.6 28.9
1 24.5 21.4	2 27.7 26.2	2 78.5 77.2	1 42.1 47.9	6 20.2 35.4
3 10.9 8.5	4 15.7 12.5	3 32.6 32.4	3 36.7 40.9	13 14.3 11.1
5 14.8 12.1	H 23 2	4 80.0 23.8	5 20.8 24.6	O K 6
H 14 2	1 35.8 36.0	0 76.7 83.1	H 14 3	0 50.6 53.5
1 54.3 54.6	2 21.6 20.5	2 37.0 35.9	4 26.4 30.5	4 26.4 30.5
2 27.6 25.2	H 24 2	4 41.6 37.6	6 42.4 43.6	8 24.7 27.5
4 17.3 19.2	0 10.5 9.8	6 28.3 27.1	4 22.6 24.9	18 10.8 13.5
H 15 2	2 10.6 10.1	H 7 3	6 16.5 16.4	18 10.8 12.4
1 62.1 55.1	H 25 2	1 29.2 30.4	H 15 3	1 K 6
3 62.1 62.4	1 14.4 11.7	3 45.3 36.8	1 10.0 7.4	1 5.2 10.3
5 23.4 22.3	H 26 2	5 7.3 12.5	3 22.8 20.4	3 25.0 24.5
H 16 2	2 20.0 20.3	7 15.1 12.5	H 16 3	5 19.8 18.9
1 46.0 42.0	2 19.8 21.3	H 8 3	H 16 3	11 28.3 28.3
2 28.3 26.7	H 27 2	0 34.5 29.5	0 25.7 27.9	15 21.2 22.5
4 29.5 24.9	1 15.3 14.6	4 19.6 17.5	2 35.7 36.5	2 K 6
6 15.7 14.4	H 17 2	6 12.9 11.4	6 11.4 12.7	0 35.2 30.7
H 17 2	3 10.2 9.1	H 9 3	H 17 3	4 6 6.7 8.2
H 18 2	1 90.7 79.4	1 57.4 58.1	1 30.8 31.4	8 26.3 25.9
1 50.7 42.0	3 62.1 62.4	3 55.8 53.7	3 22.2 23.9	12 14.7 17.5
4 24.9 22.3	4 24.9 22.3	5 27.7 26.3	H 18 3	16 5.5 10.2
H 19 2	1 41.3 39.9	6 15.6 17.6	H 19 3	3 K 6
3 30.1 36.6	3 20.1 36.6	H 10 3	0 25.1 26.2	11 17.9 16.9
5 20.8 18.1	5 20.8 18.1	0 2 2 37.0 37.0	2 2 2 37.0 37.0	5 9.6 9.2
H 20 2	0 2 2 37.0 37.0	0 2 2 37.0 37.0	2 2 2 37.0 37.0	9 9.4 7.6
1 32.0 32.4	1 32.0 32.4	0 2 2 37.0 37.0	0 2 2 37.0 37.0	11 15.2 17.9
2 28.1 25.9	2 28.1 25.9	0 2 2 37.0 37.0	0 2 2 37.0 37.0	19 16.9 21.9
4 23.7 19.3	4 23.7 19.3	1 19.8 17.2	H 20 3	0 K 7
H 21 3	H 4 4	3 7.4 5.0	0 35.3 36.6	1 23.5 19.5
1 24.8 24.8	0 55.3 57.1	5 12.0 10.8	2 25.5 28.5	3 22.8 19.8
3 23.3 23.5	2 77.8 65.1	H 12 4	4 19.7 18.6	11 15.6 4.6
H 22 3	4 45.7 41.5	H 22 4	4 19.4 20.1	2 K 7
0 19.3 16.0	6 19.9 21.1	5 4 6.5	6 7.4 11.5	2 16.7 17.1
2 9.7 9.2	H 5 4	H 13 4	H 23 4	10 14.2 15.5
4 12.1 9.5	1 36.9 32.3	1 15.8 11.4	H 24 4	3 K 7
H 23 3	3 16.9 16.3	5 57.7 7.6	5.1 6.1	1 10.0 14.0
0 19.3 16.0	5 24.7 19.8	H 14 4	O K 5	3 9.7 9.7
2 9.7 9.2	H 6 4	1 33.3 31.6	2 24.5 31.4	5 15.8 19.0
H 24 3	0 21.5 22.1	2 18.3 15.1	6 41.6 43.1	7 5.1 10.3
0 27.3 25.7	2 28.4 15.9	4 15.2 14.9	8 17.0 16.7	9 10.1 12.7
2 16.5 16.2	4 8.8 12.8	H 15 4	10 29.0 35.2	
H 25 3	H 7 4	1 39.9 39.3	12 23.8 28.0	
1 19.0 21.2	1 53.0 48.9	3 40.0 41.0	14 19.6 27.0	
H 0 4	3 34.2 33.5	5 14.6 17.5	16 17.0 15.0	
0 113.3 120.2	5 28.9 26.6	H 16 4	20 21.1 22.3	
2 66.4 60.7	H 8 4	2 28.2 26.9	22 7.5 9.3	
4 57.4 56.3	0 47.3 46.5	4 16.7 16.4	1 K 5	
6 35.1 39.4	2 55.6 49.5	H 18 4	1 42.5 41.7	
H 1 4	4 31.5 35.8	H 18 4	3 31.1 29.9	
1 10.3 14.1	6 14.4 19.8	H 9 4	5 42.6 43.0	
3 39.7 34.4	H 9 4	2 14.0 14.2	7 29.6 30.2	
7 7.6 10.2	1 20.2 16.4	4 11.5 14.3	9 3.1 33.8	
H 2 4	3 19.7 16.6	H 19 4	13 23.7 20.4	
0 14.4 11.9	5 7.6 6.6	1 27.3 28.3	17 20.3 19.3	
2 9.0 6.8	H 10 4	3 25.5 26.1	21 16.2 15.4	
H 3 4	2 28.7 24.8	H 20 4	2 42.4 40.9	
1 50.3 47.1	4 12.1 12.2	22.0 21.4	6 22.2 25.1	
3 39.3 30.9	H 11 4	2 17.4 15.9	8 10.4 15.0	
5 27.8 28.1	1 53.5 54.9	4 11.4 12.7	12 15.2 15.7	
7 8.6 12.2	3 35.0 36.5	H 21 4	14 17.1 19.3	
	5 26.6 32.1	1 16.2 14.3	16 29.9 31.6	
		3 6.0 6.2	18 22.5 21.6	
			20 15.1 14.8	

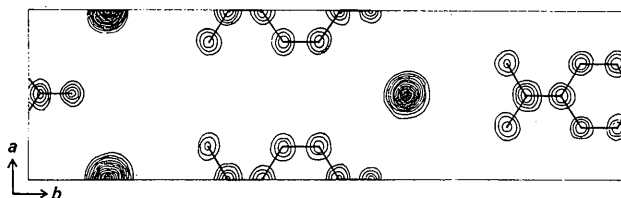
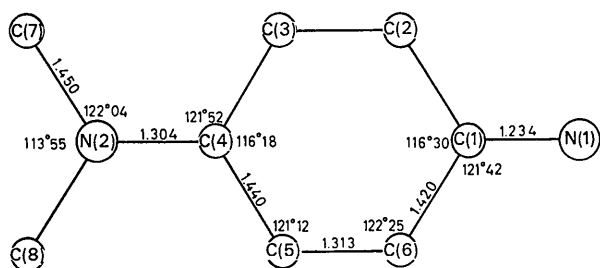

Fig. 2. Bond lengths and angles.

the positive charge on either N(1) or N(2) atoms is hardly justified from molecular orbital theory. According to the molecular orbital theory the electron is expected to be removed from the highest occupied orbital. The calculations of the bond orders were made on the free amine molecule and the cation radical by a program developed for self-consistent field molecular orbitals. The results indicate that the bond orders of C(1)-N(1), and C(2)-C(3) are increased while C(1)-C(2) is decreased in the radical, therefore the general features of the change in bond lengths can be qualitatively explained by the theory (*cf.* Fig. 3.)

It is interesting to compare the present result with that of the charge-transfer complex of *N,N,N',N'*-tetramethyl-*p*-phenylenediamine with 7,7,8-tetracyanoquinodimethane analysed by Hanson (1965). In this complex a partial electron transfer from the amine molecule to the TCNQ is expected, and the bond lengths of the amine show an apparent bond alternation as compared with free amine, for instance *p*-aminophenol (Brown, 1951). The reason for the shorter bond length in C(1)-N(1) than in C(4)-N(2) may be the intermolecular effect, since the C(1)-N(1) bond is strongly overlapped with the adjacent benzene rings. The other point to be noted in the structure is that the dimethylamino group is perfectly coplanar with the benzene ring. The situation will be probably the same for the amino group, although this point is not confirmed by the present analysis, which does not include the hydrogen atoms. This result suggests that the pure *sp*² hybridization occurs in the nitrogen atoms of the amino and the dimethylamino groups, and the conjugation of the *2p* π orbital with the benzene ring is perfect. It is interesting to compare this result with aniline in the vapour phase in which the NH₂ plane is tilted by 46° to the ring-to-N bond (Lister & Tyler, 1966; Brand, Williams & Cook, 1966).

Packing of the Würster radical

The Würster's radicals are in infinite chains separated by equal distances, the interplanar separation between the parallel benzene rings being 3.105 Å. Although in some charge transfer complex crystals an interplanar spacing of about 3.20 Å is known to exist, the value in the present study is the shortest interplanar spacing among known structures. The unpaired electron on each radical will form a covalent bond between the radicals.

The charge-resonance interaction is certainly important but the intermolecular binding will be opposed by a Coulomb repulsion between the positive charges on the whole molecular cation and by the exchange repulsion of the closed shell electrons. The balance of these several forces will result in a shortening of the interplanar separation compared with the usual van der Waals radii. It is also interesting that the electrostatic forces between the radical cations and the bromide anion does not seem to play any particular role in the binding of the two radical cations. Instead, the covalent

and charge-resonance forces of the unpaired electrons play an important role at such a short interplanar separation of 3.2 Å.

From the theoretical viewpoint Ooshika (1957) and Longuet-Higgins & Salem (1959) have shown that the most stable configuration of an infinite conjugated system results when alternation of the interradical bond distance takes place. Thomas, Keller & McConnell (1963) argued on this basis that Würster's blue perchlorate, intermolecular spacing in which is known to be equidistant at room temperature, was transformed to the dimeric form at lower temperature. Such a transition has not yet been found in the present crystal.

The interatomic distances less than 3.40 Å between the two benzene rings are shown in Fig. 4. It is found that the shortest distance is 3.18 Å, and the other distances are usually longer than 3.20 Å. The overlapping of two radicals is illustrated in Fig. 5. It is interesting that the stacking of molecules occurs in such a way that one molecule is displaced relatively to the other and the amino group of one is situated above the benzene ring of the other. This type of configuration is often observed in other charge transfer complexes such as quinhydrone (Matsuda, Osaki & Nitta, 1958; Sakurai 1965), TCNQ complexes (Fritchie, 1966), and some benzoquinone complexes (Wallwork, 1961).

The thermal motion of the radical is shown in Fig. 6, the anisotropic temperature factors of Table 3 being used. It is apparent that the molecular motion is greatest along the out-of-plane direction, except for the C(1) atom where the out-of-plane motion seems to be sterically hindered by the neighbouring atoms. The rotation around the molecular axis is also large, while the motion at the terminal dimethylamino group is largest.

Finally the interaction between the bromide anion and the Würster's cation should be mentioned. The shortest distance between the bromine and the radical takes place for N(1)...Br(3.46 Å). It is conceivable that a weak hydrogen bonding may exist here. Another bromide anion which is coplanar with the radical is on the other side of it, alongside the dimethylamino group. The role of those anions in the crystal will be to make whole ionic lattice neutral, although it has no particular affinity to the cation radicals.

References

- BRAND, J. C. D., WILLIAMS, D. R. & COOK, T. J. (1966). *J. Mol. Spect.* **20**, 359.
 BROWN, C. J. (1951). *Acta Cryst.* **4**, 100.
 FRITCHIE, C. J., JR. (1966). *Acta Cryst.* **20**, 892.

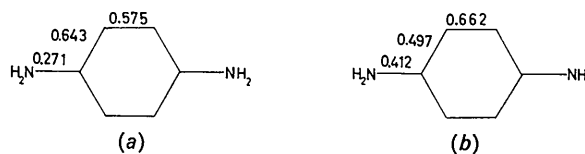

Fig. 3. Bond orders for (a) the *p*-phenylenediamine molecule and (b) the *p*-phenylenediamine radical calculated by a SCF MO method.

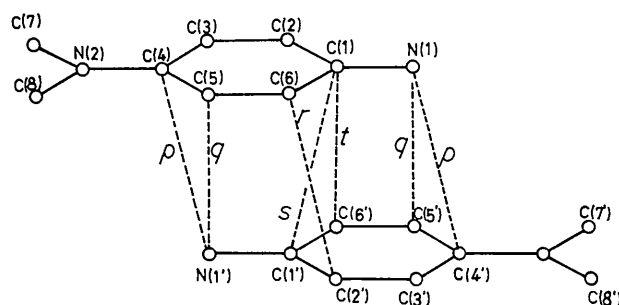

Fig. 4. Intermolecular distances between adjacent radicals. *p*, N(1)...C(4'), N(1')...C(4), 3.20 Å; *q*, N(1)...C(3'), C(5'); N(1')...C(3), C(5), 3.21 Å; *r*, C(2)...C(6'), C(2')...C(6), 3.18 Å; *s*, C(1)...C(1'), 3.21 Å; *t*, C(1)...C(2), C(6), 3.33 Å.

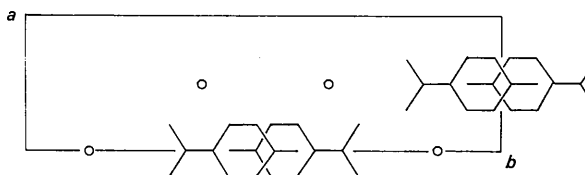

Fig. 5. Overlapping of two radicals projected on the (001) plane. Circles indicate bromide anions.

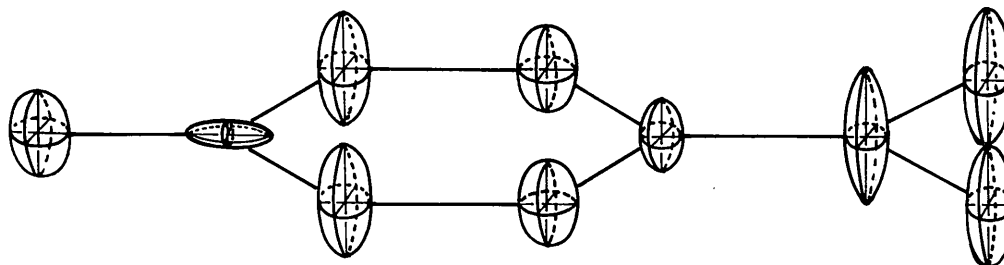

Fig. 6. Plot of thermal displacement ellipsoid.

Table 3. Final thermal parameters U_{ij}

	U_{11}	U_{22}	U_{33}	U_{12}	U_{31}	U_{23}
Br	0.7296	0.7191	0.8846	0.0000	0.0000	0.0000
N(1)	0.9197	0.2481	1.7962	0.0000	0.0000	0.0000
N(2)	1.0066	0.4402	1.0032	0.0000	0.0000	0.0000
C(1)	0.4819	0.5160	1.0606	0.0000	0.0000	0.0000
C(2)	0.4089	0.8045	1.1151	-0.0312	0.0000	0.0000
C(3)	0.4428	0.7014	1.4909	0.0786	0.0000	0.0000
C(4)	0.6311	1.0532	0.4299	0.0000	0.0000	0.0000
C(7)	0.8676	0.5670	1.8886	-0.3743	0.0000	0.0000

HANSON, A. W. (1965). *Acta Cryst.* **19**, 610.

LISTER, D. G. & TYLER, J. K. (1966). *Chem. Commun.* p. 152.

LONGUET-HIGGINS, H. C. & SALEM, L. (1959). *Proc. Roy. Soc. (London)*, **A251**, 172.

MATSUDA, H., OSAKI, K. & NITTA, I. (1958). *Bull. Chem. Soc. Japan*, **31**, 611.

OOSHIKA, Y. (1957). *J. Phys. Soc. Japan*, **12**, 1246.

SAKURAI, T. (1965). *Acta Cryst.* **19**, 320.

THOMAS, D. D., KELLER, H. & MCCONNELL, H. M. (1963). *J. Chem. Phys.* **39**, 2321.

TURNER, J. D. & ALBRECHT, A. C. (1955). Unpublished result. See *J. Amer. Chem. Soc.* (1955), **77**, 4454 and *J. Chem. Phys.* (1963), **39**, 2321.

WALLWORK, S. C. (1961). *J. Chem. Soc.* p. 494.

Acta Cryst. (1968). **B24**, 1349

The Crystal and Molecular Structure of L-Aspartic Acid

BY J. L. DERISSEN, H. J. ENDEMAN AND A. F. PEERDEMAN

Laboratorium voor Kristalchemie, Rijksuniversiteit, Utrecht, The Netherlands

(Received 6 May 1968)

Crystals of L-aspartic acid are monoclinic ($P2_1$) with $a=7.617$, $b=6.982$, $c=5.142$ Å, $\beta=99.84^\circ$, $Z=2$. The crystals are often more or less twinned. The structure was solved in the $h0l$ projection by the Patterson vector shift method. The structure was refined with 602 diffractometer hkl data to a final R value of 0.04. The molecules are in the zwitterionic form. A rigid three-dimensional network of intermolecular 'hydrogen bonds' is found.

Introduction

As one of the group of naturally occurring α -amino acids, L-aspartic acid is a very important compound. However, the molecular structure had not previously been determined.

A few questions arise with respect to this structure:

- (1) Is there a planar carbon skeleton or is the skeleton non-planar as in L-asparagine?
- (2) Is the structure zwitterionic as in other α -amino acids?
- (3) Is there evidence for an intramolecular hydrogen bond or are all the hydrogen bonds of the common intermolecular type? (In so far as we may speak of hydrogen bonds between charged groups.) The purpose of this study is to answer these questions and to present an accurate set of molecular parameters for the crystalline state.

Experimental

The sample used was from Fluka A.G. Buchs S.G. (puriss.). Crystals were obtained by slow evaporation of an aqueous solution at room temperature.

The cell constants have been reported as (Bernal, 1931): $a=15.1$, $b=6.9$, $c=5.1$ Å, $\beta=96^\circ$, space group $P2_1$, $Z=4$. These data were roughly confirmed by oscillation photographs. Weissenberg photographs, however, showed very strange extinctions: for h =odd and l =even all reflexions were absent. Also, different crystals showed very big relative intensity differences; it appears that twinning occurs in different degrees. The geometric twinning condition fulfilled in this case is that the diagonal of the a - c plane is equal to the a unit-cell dimension (both according to Bernal's cell dimensions). The twinning situation is shown in Fig. 1.

The common reciprocal axis of the two lattices is a^* , the double cell according to Bernal is shown as the reciprocal 'cell' $ABCD$. The extinctions are easily seen in this Figure. The conclusion is that the cell dimension a should be halved, consequently $Z=2$ with only one molecule in the asymmetric unit. We tried to find an untwinned crystal, and a crystal that was nearly untwinned was found and was used throughout this structure determination.

As for l odd, the reflexions from the two lattices are seen separately and the degree of twinning can be measured from these reflexions. This was done on an $h0l$ Weissenberg diagram with the only two of these reflexions which were strong enough to be seen in both